

HOSE COUPLING SK100 to EN 561 / ISO 7289



WITT-Couplings guarantee safety

- no uncontrolled escape of gas when disconnected – because of automatic cut off valve
- no build-up of explosive gas-mixtures in the pipe line – because of non return valve
- no confusion between connection – because of different probes for Oxygen, Fuel and Inert Gases
- kink free hose and secure connection – because of ball race lock



WITT-Couplers save time and money

- lightning fast connection and disconnection of equipment
- simplest selection of the right body and probe – because new colour coded probe
- flexible extensions of hoses without additional equipment
- easiest suction test for injector burner without tool



WITT-Couplings for long life

- probe made from stainless steel with hardness of 25 Rockwell
- dirt-filter protects hose coupling and equipment

SK100-1/2 body
SK100-1 probe

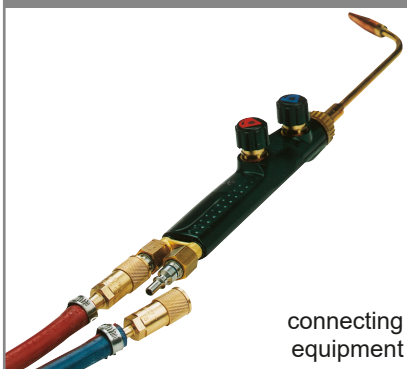

connecting equipment

SK100-1/2 body
SK100-2/3 probe

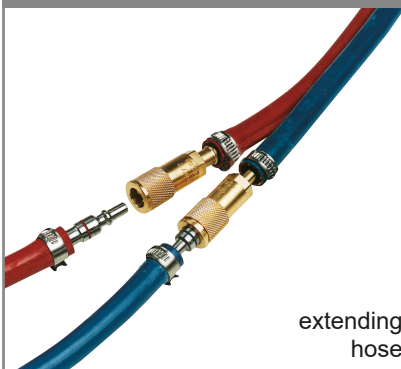

extending hose

SK100-3 body
SK100-2/3 probe

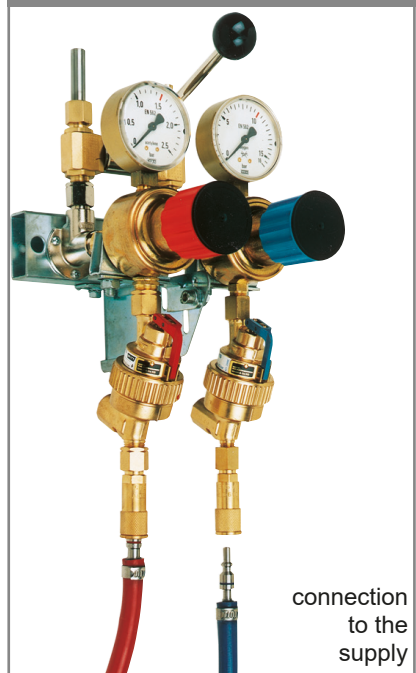

connection to the supply

SK100 USA - D02/5B subject to change

HOSE COUPLING SK100

to EN 561 / ISO 7289

Model	Connection EN 560		body part no.	probe part no.
	Inlet	Outlet		
SK100-1 Fuel Gas	nozzle Ø 4.0 mm	G 3/8 LH	150-001	151-001
	nozzle Ø 5.0 mm		150-002	
	nozzle Ø 6.3 mm		150-003	
	nozzle Ø 8.0 mm		150-004	
	nozzle Ø 9.0 mm		150-005	
Oxygen (O)	nozzle Ø 4.0 mm	G 1/4 RH	150-007	151-003
	nozzle Ø 5.0 mm		150-008	
	nozzle Ø 6.3 mm		150-009	
	nozzle Ø 8.0 mm		150-010	
Inert Gases	nozzle Ø 6.3 mm	G 1/4 RH	150-013	151-005
SK100-2 Fuel Gas	nozzle Ø 4.0 mm	nozzle Ø 4.0 mm	150-001	151-007
	nozzle Ø 5.0 mm	nozzle Ø 5.0 mm	150-002	151-008
	nozzle Ø 6.3 mm	nozzle Ø 6.3 mm	150-003	151-009
	nozzle Ø 8.0 mm	nozzle Ø 8.0 mm	150-004	151-010
	nozzle Ø 9.0 mm	nozzle Ø 9.0 mm	150-005	151-011
Oxygen (O)	nozzle Ø 4.0 mm	nozzle Ø 4.0 mm	150-007	151-013
	nozzle Ø 5.0 mm	nozzle Ø 5.0 mm	150-008	151-014
	nozzle Ø 6.3 mm	nozzle Ø 6.3 mm	150-009	151-015
	nozzle Ø 8.0 mm	nozzle Ø 8.0 mm	150-010	151-016
Inert Gases	nozzle Ø 6.3 mm	nozzle Ø 6.3 mm	150-013	151-021
SK100-3 Fuel Gas	G 3/8 LH	nozzle Ø 4.0 mm	150-015	151-007
		nozzle Ø 5.0 mm		151-008
		nozzle Ø 6.3 mm		151-009
		nozzle Ø 8.0 mm		151-010
Oxygen (O)	G 1/4 RH	nozzle Ø 4.0 mm	150-017	151-013
		nozzle Ø 5.0 mm		151-014
		nozzle Ø 6.3 mm		151-015
		nozzle Ø 8.0 mm		151-016
Inert Gases	G 1/4 RH	nozzle Ø 5.0 mm	150-019	151-020
		nozzle Ø 6.3 mm		151-021

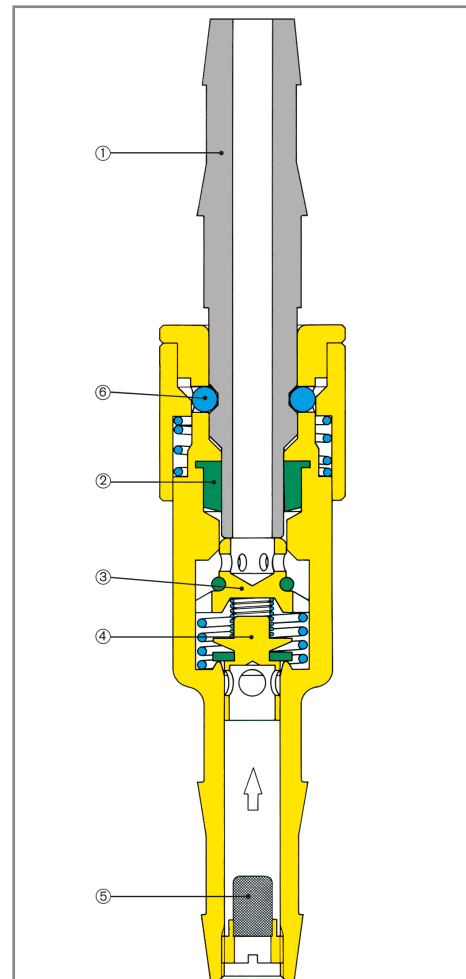

- ① **Probe**
Rust and corrosion resistant stainless steel with a minimum hardness of 25 Rockwell.
- ② **Seal**
Seals the probe before gas can flow.
- ③ **Automatic cut-off valve**
Prevents dangerous escape of gases when disconnected.
- ④ **Non-return valve**
Prevents dangerous backfeeding of gases.
- ⑤ **Dirt filter**
Prevents damage by dirt or particles.
- ⑥ **Safety lock**
Locks the probe securely in place.

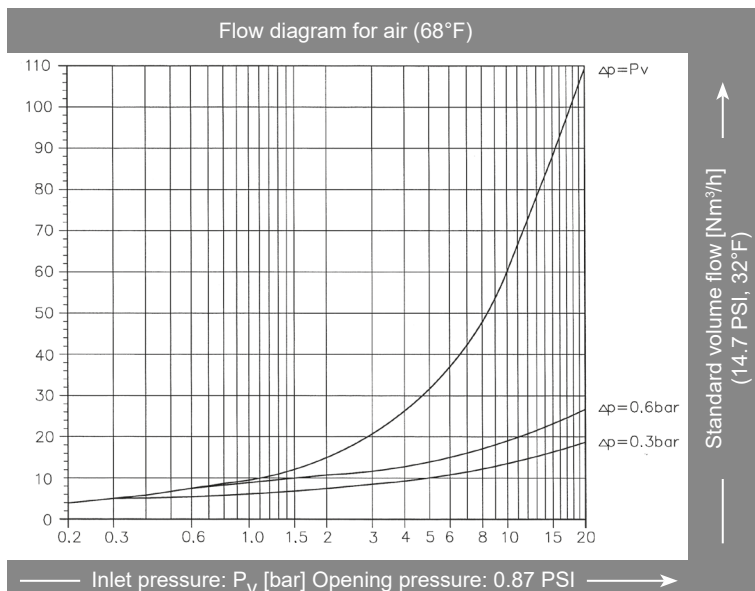

max. working pressure [PSI]	
Acetylene (A)	22
other Fuel Gases	290
Inert Gases	290
Oxygen (O)	290